

Equilibrium conditions (3D)

$$\vec{R} = \sum \vec{F} = 0 \quad \xrightarrow{\text{or}} \quad \begin{aligned} \Sigma F_x &= 0 \\ \Sigma F_y &= 0 \\ \Sigma F_z &= 0 \end{aligned}$$

$$\vec{M} = \sum \vec{M} = 0 \quad \xrightarrow{\text{or}} \quad \begin{aligned} \Sigma M_x &= 0 \\ \Sigma M_y &= 0 \\ \Sigma M_z &= 0 \end{aligned}$$

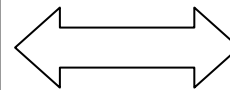

**Body (bodies)
in Equilibrium**

- Principle is the same as in 2D
- Vector approach may be easier

Modeling the action of forces (1)

1. Member in contact with smooth surface, or ball-supported member

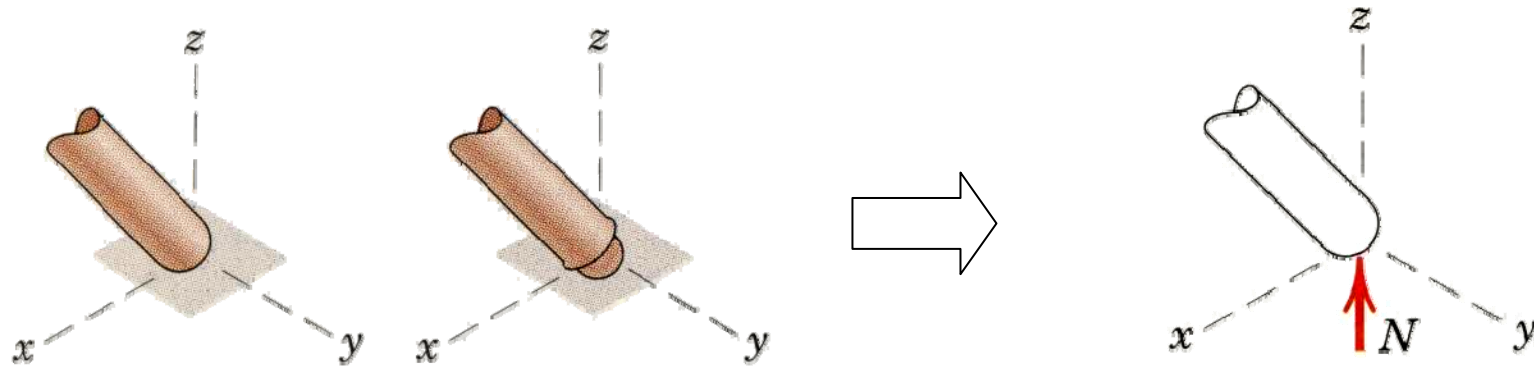

2. Member in contact with rough surface

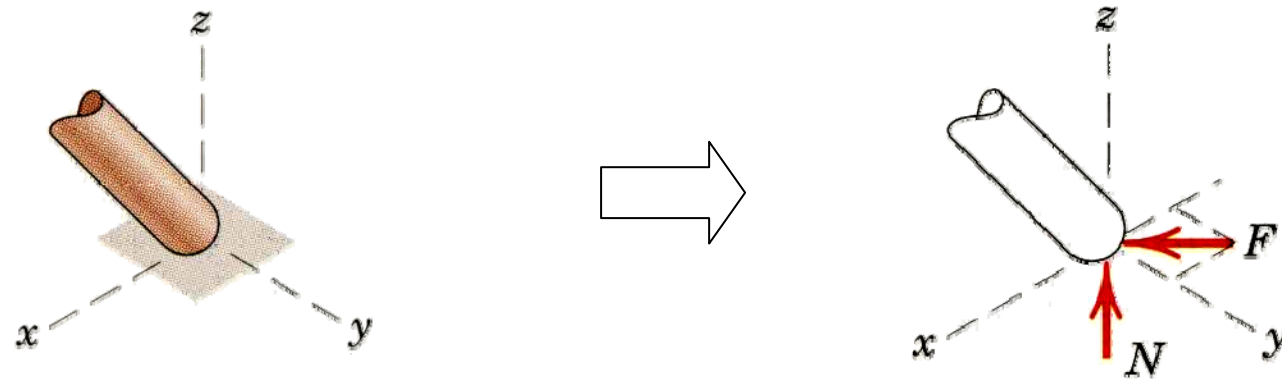

Modeling the action of forces (2)

3. Roller or wheel support with lateral constraint

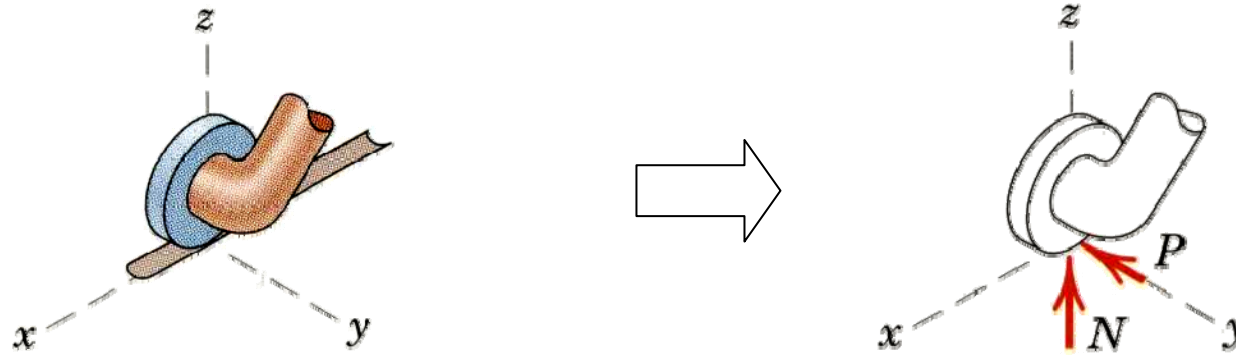

4. Ball-and-socket joint

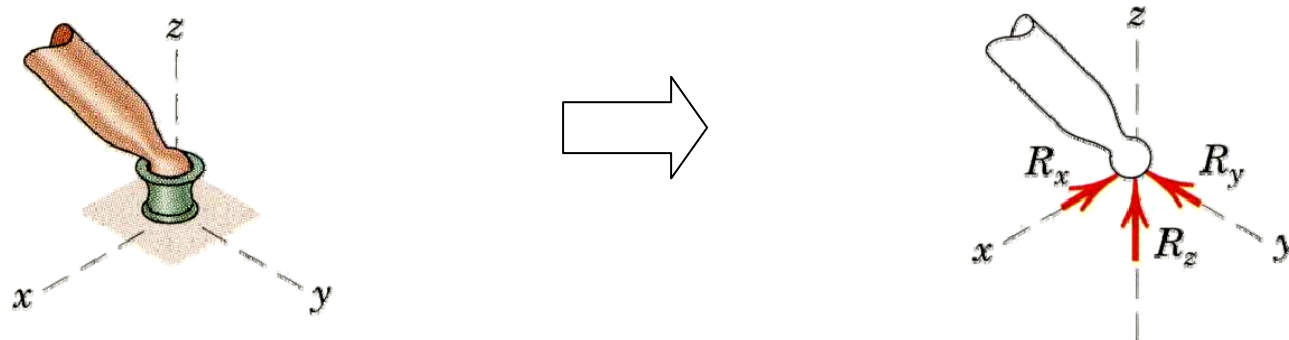

Modeling the action of forces (3)

5. Fixed connection (embedded or welded)

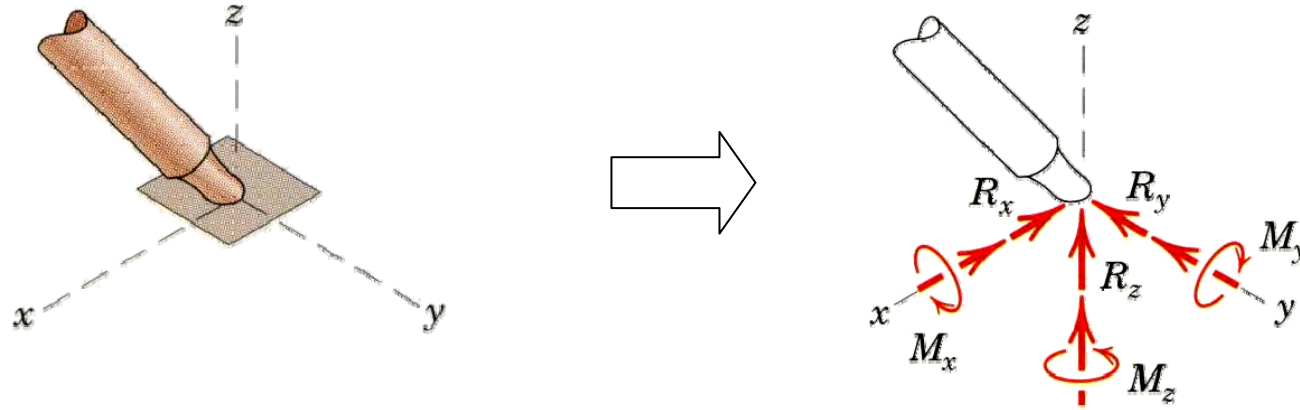

6. Thrust-bearing support

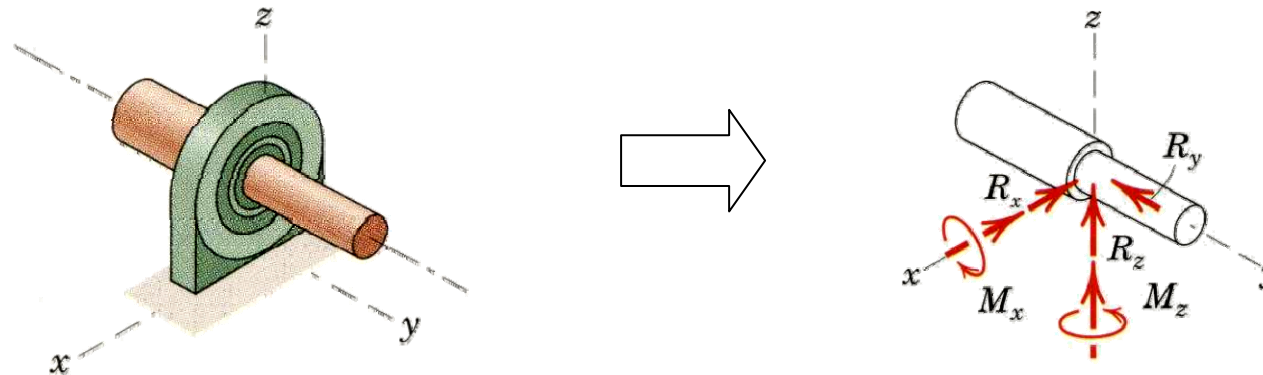

for some problem, the couple must be assumed zero to provide statical determinacy)

Categories of equilibrium (1)

1. Concurrent at a point

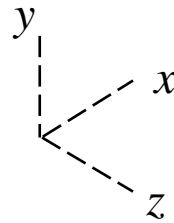
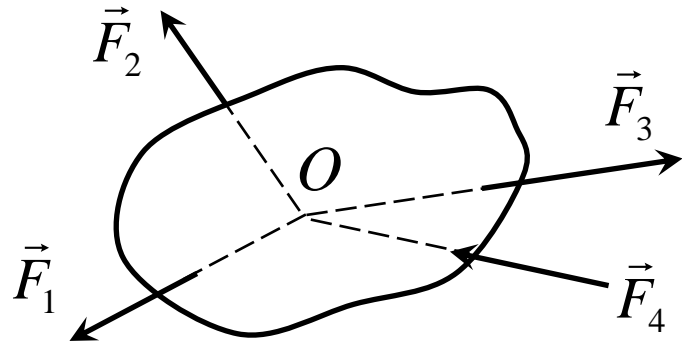

$$\begin{aligned}\sum F_x &= 0 \\ \sum F_y &= 0 \\ \sum F_z &= 0\end{aligned}$$

2. Concurrent with a line

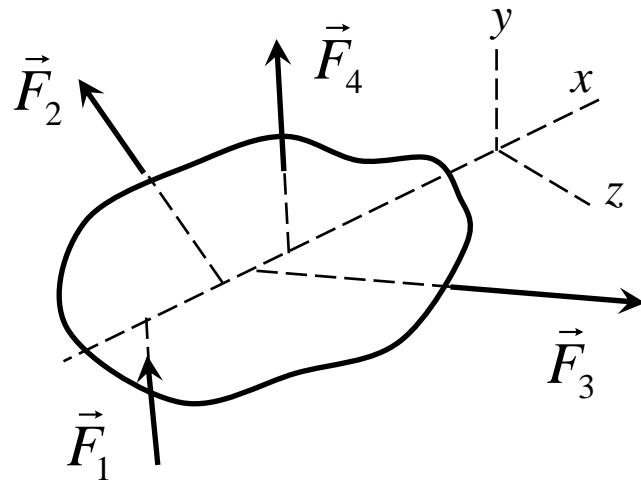

$$\begin{aligned}\sum F_x &= 0 & \sum M_y &= 0 \\ \sum F_y &= 0 & \sum M_z &= 0 \\ \sum F_z &= 0\end{aligned}$$

Categories of equilibrium (2)

3. Parallel

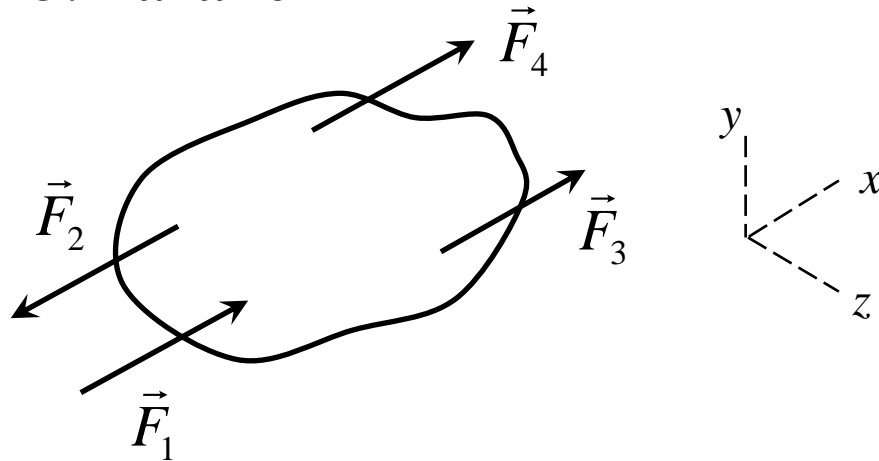

$$\sum F_x = 0 \quad \sum M_y = 0$$
$$\sum M_z = 0$$

4. General

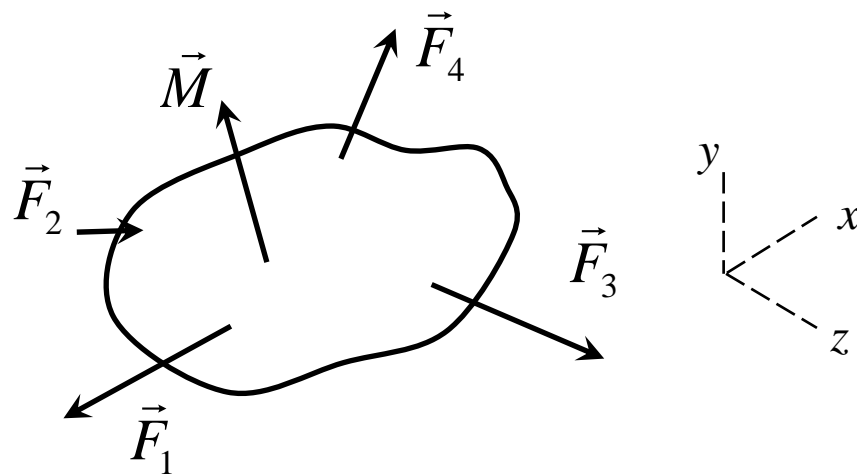

$$\sum F_x = 0 \quad \sum M_x = 0$$
$$\sum F_y = 0 \quad \sum M_y = 0$$
$$\sum F_z = 0 \quad \sum M_z = 0$$

Constraints and statical determinacy (1)

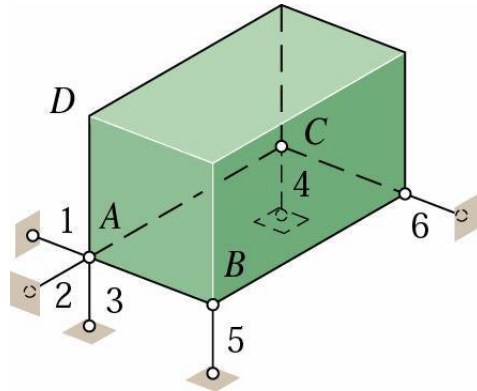

(a) Complete fixity
Adequate constraints

- Link 1,2,3: Complete fix in x,y,z direction
- Link 4,5,6: Prevent rotation

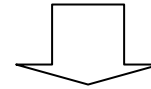

Adequate constraints

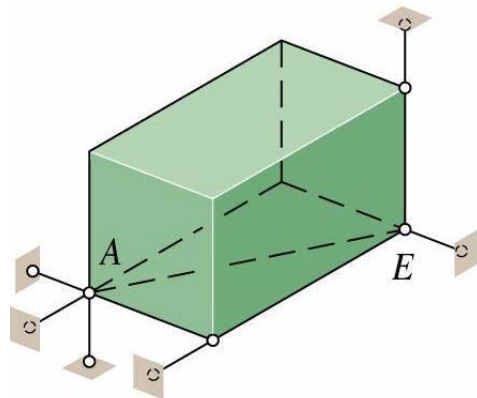

(b) Incomplete fixity
Partial constraints

- Directions of all forces are concurrent with line AE
- Moment about AE axis cannot be supported

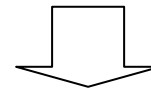

Partial constraints

Constraints and statical determinacy (2)

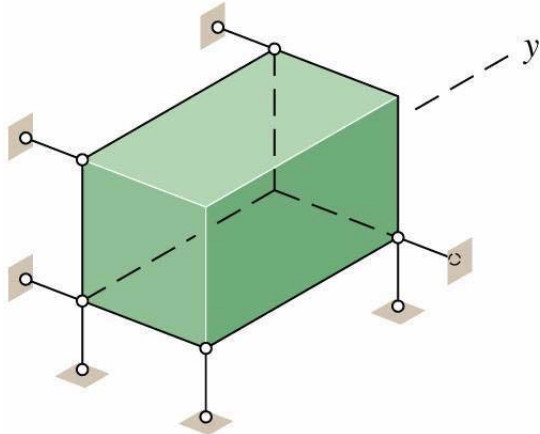

(c) Incomplete fixity
Partial constraints

Force in the y direction cannot be supported

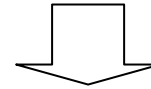

Partial constraints

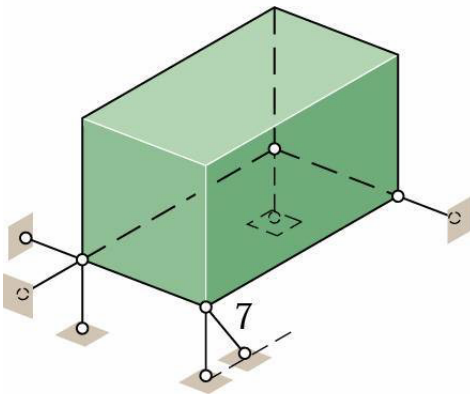

(d) Excessive fixity
Redundant constraints

- Link 1-6 are placed properly for complete fixity.
- Link 7 is redundant

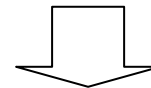

Redundant constraints

Sample 1

The uniform 7-m steel shaft has a mass of 200 kg and is supported by a ball and socket joint at A in the horizontal floor. The ball end B rests against the smooth vertical walls as shown. Compute the forces exerted by the walls and the floor on the ends of the shaft.

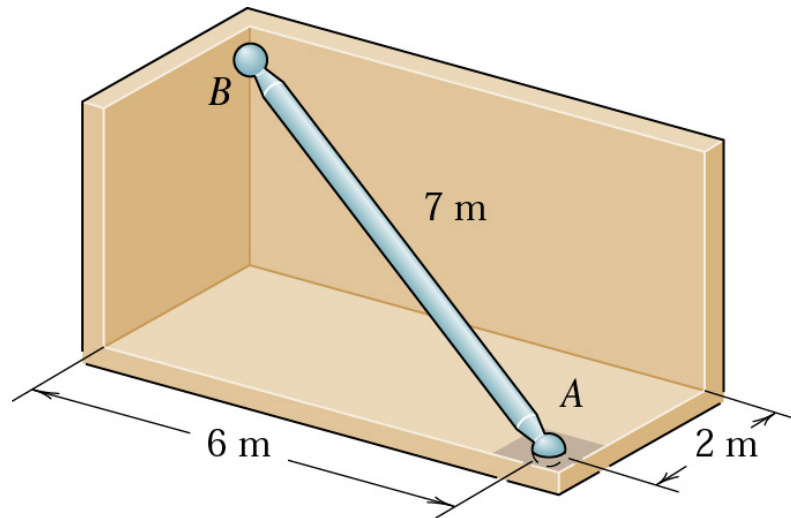

Sample 2

A 200-N force is applied to the handle of the hoist in the direction shown. The bearing *A* supports the thrust (force in the direction of the shaft axis), while bearing *B* supports only radial load (load normal to the shaft axis). Determine the mass *m* which can be supported and the total radial force exerted on the shaft by each bearing. Assume neither bearing to be capable of supporting a moment about a line normal to the shaft axis.

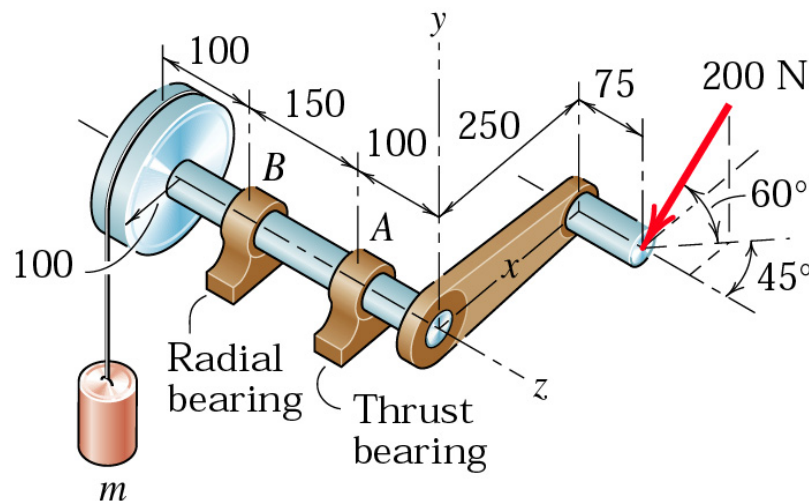

Dimensions in millimeters

Sample 3

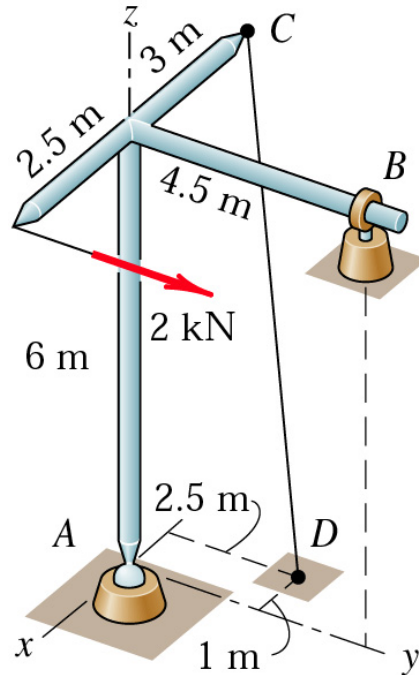

The welded tubular frame is secured to the horizontal x - y plane by a ball-and-socket joint at A and receives support from the loose-fitting ring at B . Under the action of the 2-kN load, rotation about a line from A to B is prevented by the cable CD , and the frame is stable in the position shown. Neglect the weight of the frame compared with the applied load and determine the tension T in the cable, the reaction at the ring, and the reaction components at A .

Sample 4

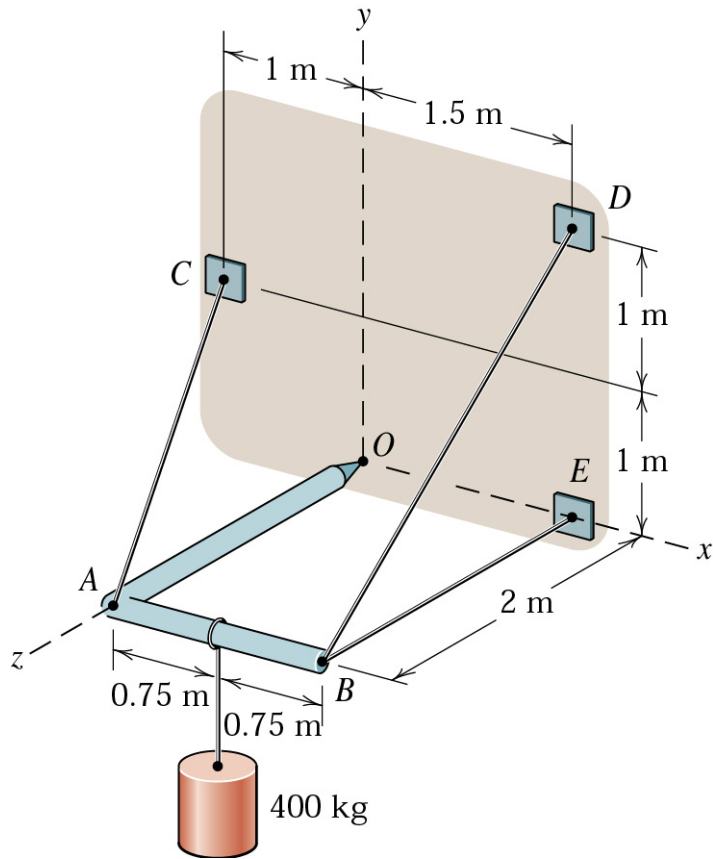

The light right-angle boom which supports the 400-kg cylinder is supported by three cables and a ball-and-socket joint at O attached to the vertical x - y surface. Determine the reactions at O and the cable tensions.

Sample 5

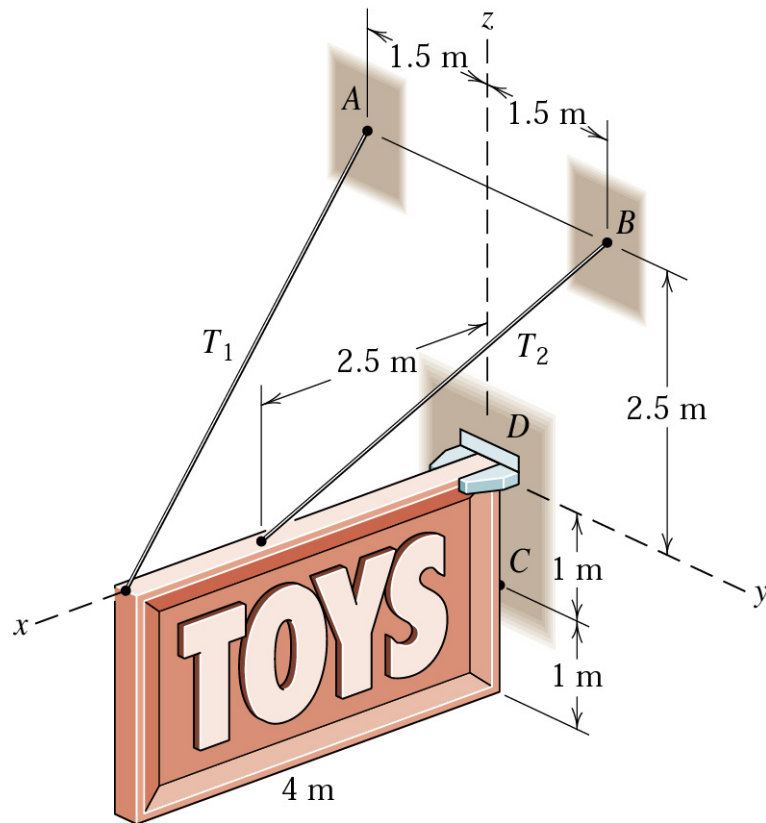

A rectangular sign over a store has a mass of 100 kg, with the center of mass in the center of the rectangular. The support against the wall at point C may be treated as a ball-and-socket joint. At corner D support is provided in the y -direction only. Calculate the tension T_1 and T_2 in the supporting wires, the total force supported at C , and the lateral force R supported at D .

Sample 6

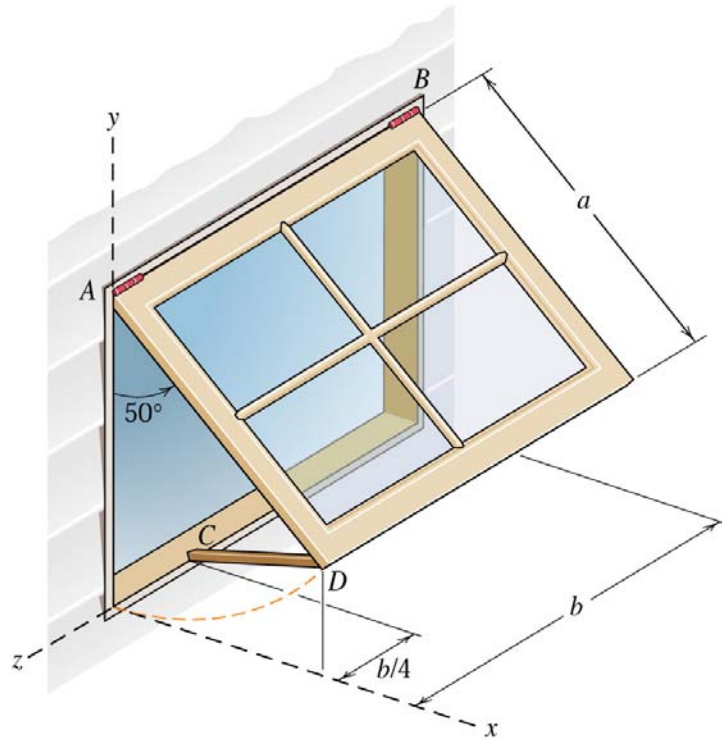

The awning window is temporarily held open in the 50° position shown by a wooden prop CD . If $a = 0.8$ m and $b = 1.2$ m and the mass of the window is 50 kg with mass center at its geometric center, determine the compressive force F_{CD} in the prop and all components of the forces exerted by the hinges A and B on the window. Assume that A is a thrust-bearing hinge but that hinge B is not.