

Applications of force vibration

- Rotating unbalance
- Base excitation
- Vibration measurement devices

Rotating unbalance (1)

Rotating unbalance: Vibration caused by irregularities in the distribution of the mass in the rotating component.

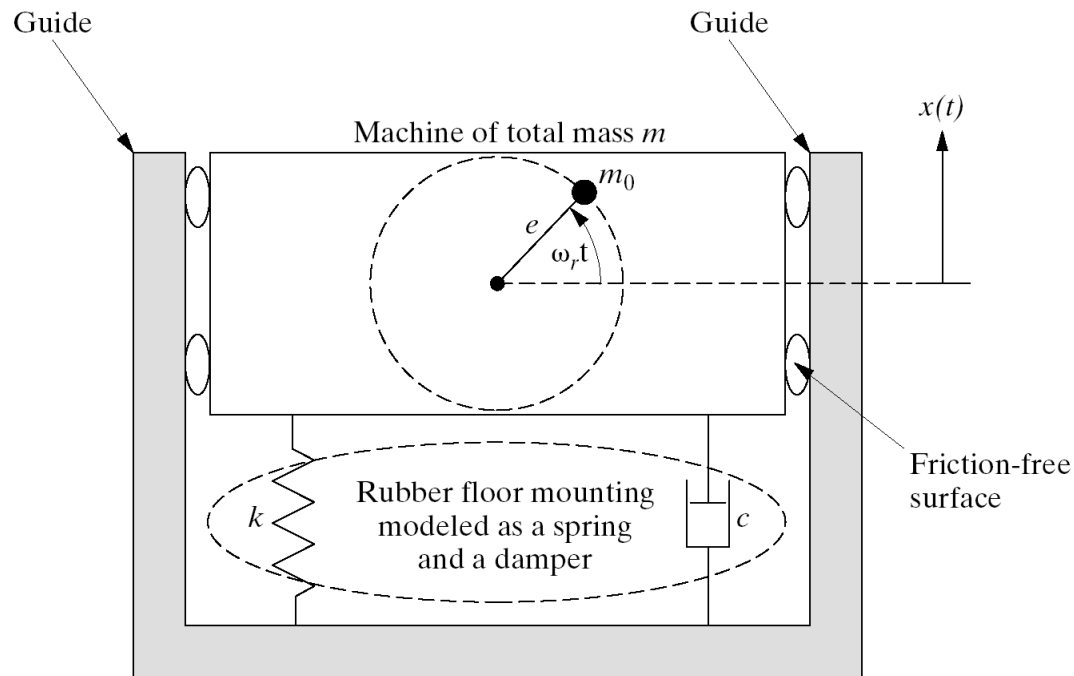

Rotating unbalance (2)

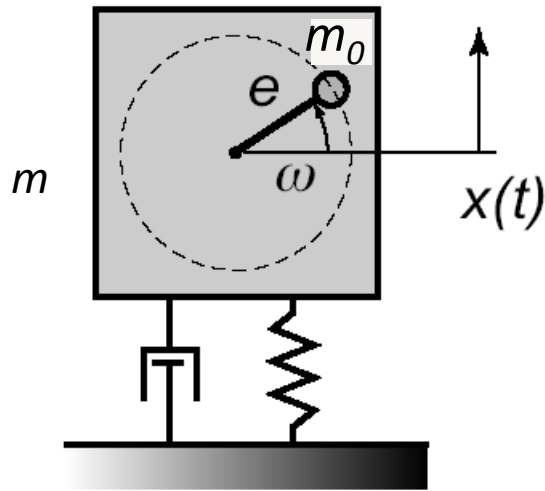

FBD 1

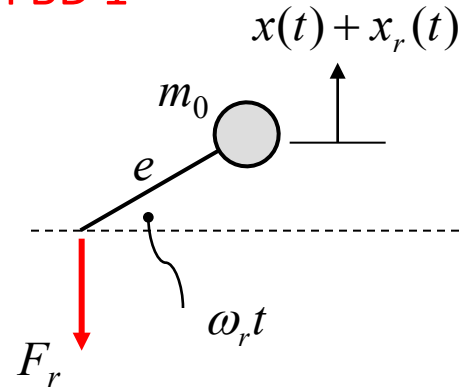

FBD 2

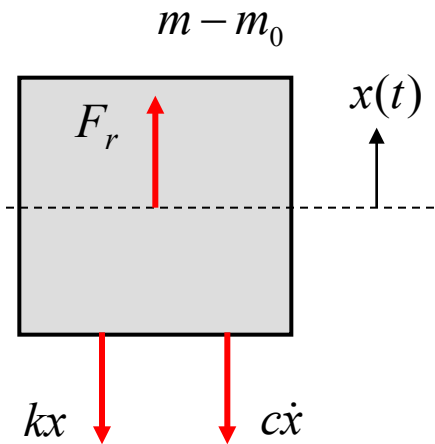

FBD 1

$$m_0(\ddot{x} + \ddot{x}_r) = -F_r$$

FBD 2

$$(m - m_0)\ddot{x} = F_r - c\dot{x} - kx$$

$$m\ddot{x} + m_0\ddot{x}_r + c\dot{x} + kx = 0$$

$$x_r = e \sin \omega_r t$$

$$\ddot{x}_r = -e\omega_r^2 \sin \omega_r t$$

$$m\ddot{x} + c\dot{x} + kx = m_0 e \omega_r^2 \sin \omega_r t$$

Rotating unbalance (3)

$$m\ddot{x} + c\dot{x} + kx = m_0 e \omega_r^2 \sin \omega_r t \quad \Rightarrow$$

$$\ddot{x} + 2\zeta\omega_n\dot{x} + \omega_n^2 x = \frac{m_0 e}{m} \omega_r^2 \sin \omega_r t$$

$$z(t) = Ze^{j\omega_r t}, \quad x(t) = \text{Im}[z(t)]$$

$$\ddot{z} + 2\zeta\omega_n\dot{z} + \omega_n^2 z = \frac{m_0 e}{m} \omega_r^2 e^{j\omega_r t}$$

$$Z = \frac{m_0 e}{m} \left[\frac{\omega_r^2}{\omega_n^2 - \omega_r^2 + j2\zeta\omega_n\omega_r} \right] = \frac{m_0 e}{m} \left[\frac{r^2}{1 - r^2 + j2\zeta r} \right]$$

$H(\omega)$

$$x(t) = \frac{m_0 e}{m} |H(\omega)| \sin(\omega_r t + \theta);$$

$$\theta = -\tan^{-1} \frac{2\zeta r}{1 - r^2}$$

Rotating unbalance (4)

$$x(t) = \frac{m_0 e}{m} |H(\omega)| \sin(\omega_r t + \theta) = X \sin(\omega_r t + \theta)$$

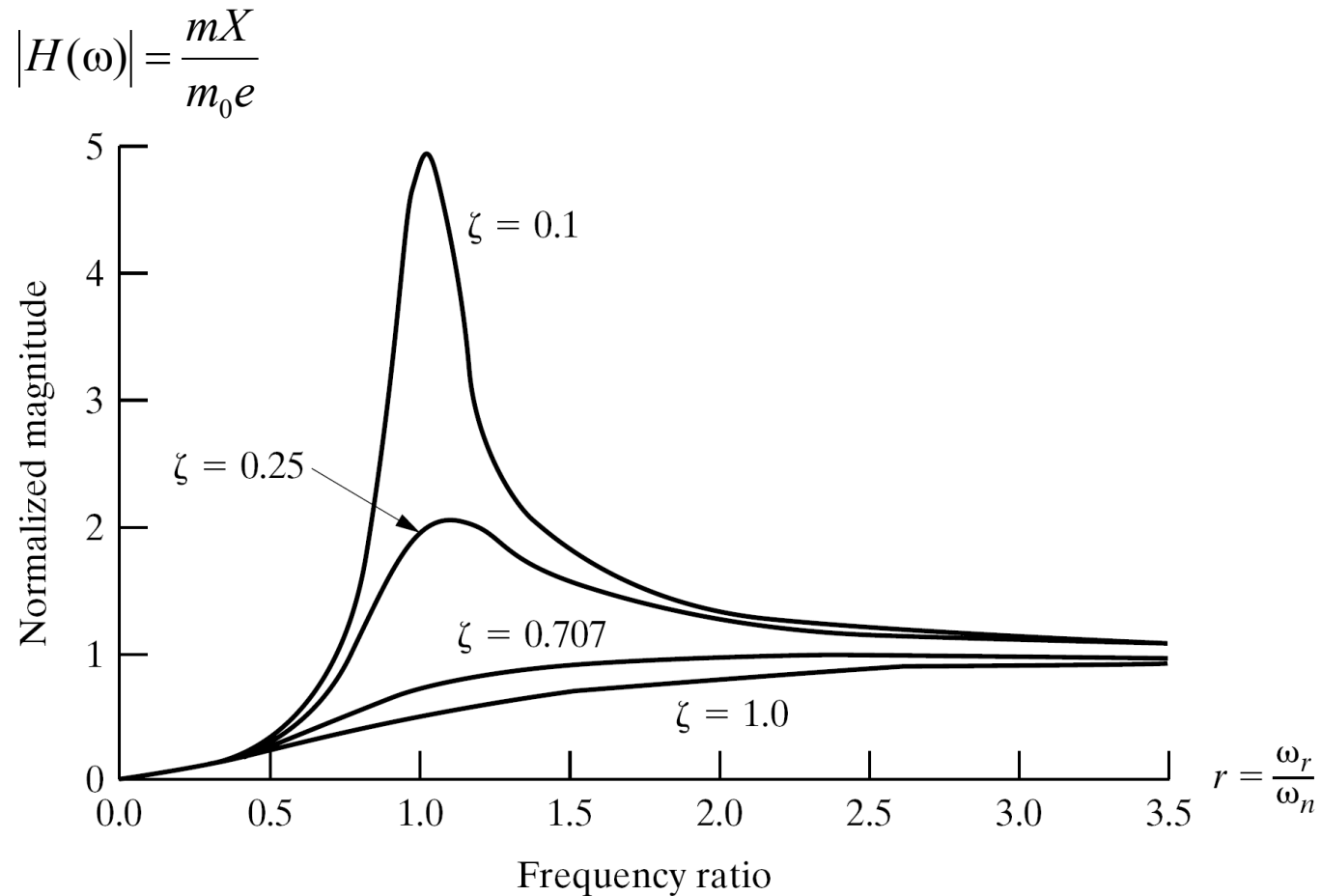

Example: washing machine

A model of a washing machine is illustrated in the figure. A bundle of wet clothes form a mass of 10 kg (m_0) and causes a rotating unbalance. The rotating mass id 20 kg (including m_0) and the diameter of the washer basket ($2e$) is 50 cm. Assume that the spin cycle rotates at 300 rpm. Let k be 1000 N/m and $\zeta = 0.01$. (a) Calculate the force transmitted to the sides of the washing machine. (b) The quantities m , m_0 , e and ω are all fixed by the previous design. Design the isolation system so that the force transmitted to the side of the washing machine is less than 100 N.

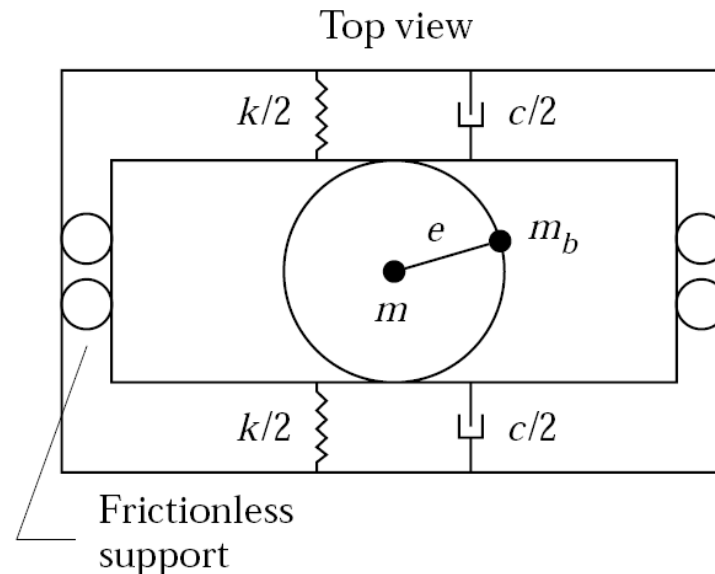

Example: Unbalance motor

An electric motor has an eccentric mass of 1 kg (10% of the total mass) and is set on two identical springs ($k = 3.2 \text{ N/mm}$). The motor runs at 1750 rpm, and the mass eccentricity is 100 mm from the center. The springs are mounted 250 mm apart with the motor shaft in the center. Neglect damping and determine the amplitude of vertical vibration.

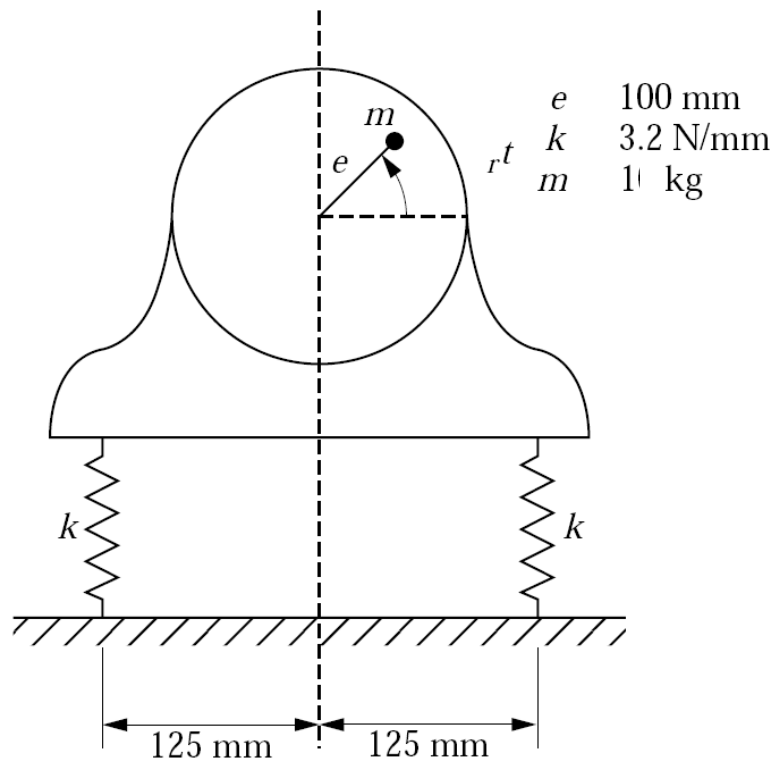

Base excitation (intro)

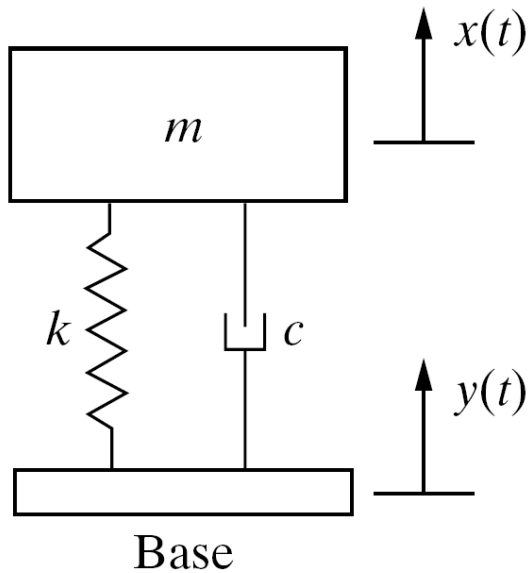

Examples

- Sensitive equipment placed on vibrating foundation
- An automotive suspension system
- Buildings subjected to earthquakes

Base excitation (1)

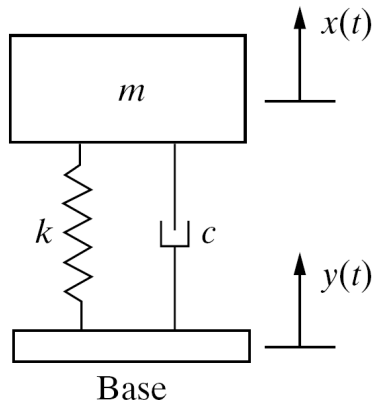

FBD

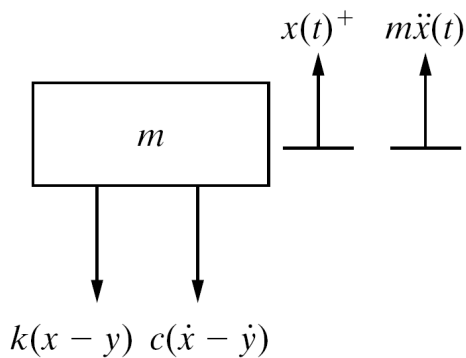

EOM $m\ddot{x} + c(\dot{x} - \dot{y}) + k(x - y) = 0$

Assumption: the base moves harmonically

$$y(t) = Y \cos \omega_b t$$

1st method: superposition

$$m\ddot{x} + c\dot{x} + kx = -cY\omega_b \sin \omega_b t + kY \cos \omega_b t$$



1st harmonic input



2nd harmonic input



$$x_p = (x_p)_1 + (x_p)_2$$

Base excitation (2)

2nd method: Frequency response method

$$m\ddot{x} + c\dot{x} + kx = c\dot{y} + ky \quad \Rightarrow \quad \ddot{x} + 2\zeta\omega_n\dot{x} + \omega_n^2x = 2\zeta\omega_n\dot{y} + \omega_n^2y$$

$$y(t) = Y \cos \omega_b t = \text{Re}[Ye^{j\omega_b t}]$$

$$z(t) = Ze^{j\omega_b t}, \quad x(t) = \text{Re}[z(t)]$$

Sub. into EOM to change to complex form

Complex EOM

$$\ddot{z} + 2\zeta\omega_n\dot{z} + \omega_n^2z = j2\zeta\omega_n\omega_bYe^{j\omega_b t} + \omega_n^2Ye^{j\omega_b t}$$

$$\left(-\omega_b^2 + j2\zeta\omega_n\omega_b + \omega_n^2\right)Ze^{j\omega_b t} = \left(j2\zeta\omega_n\omega_b + \omega_n^2\right)Ye^{j\omega_b t}$$

$$Z = \frac{\omega_n^2 + (2\zeta\omega_b\omega_n)j}{-\omega_b^2 + \omega_n^2 + (2\zeta\omega_b\omega_n)j} Y = \left[\frac{1 + (2\zeta r)j}{1 - r^2 + (2\zeta r)j} \right] Y \quad ; \quad r = \omega_b / \omega_n$$

Base excitation (3)

$$Z = \left[\frac{1 + (2\zeta r)j}{1 - r^2 + (2\zeta r)j} \right] \cdot Y = H(\omega) \cdot Y$$

$$H(\omega) = \left[\frac{1 + (2\zeta r)j}{1 - r^2 + (2\zeta r)j} \right]$$

$$Z = |H(\omega)| \cdot e^{j\theta} \cdot Y$$

$$z(t) = Ze^{j\omega_b t} \quad \Longrightarrow \quad z(t) = |H(\omega)| \cdot e^{j\theta} \cdot Y \cdot e^{j\omega_b t} = |H(\omega)| \cdot Y e^{j(\omega_b t + \theta)}$$

$$x(t) = \text{Re}[z(t)] \quad \Longrightarrow \quad x(t) = |H(\omega)| \cdot Y \cos(\omega_b t + \theta)$$

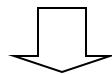

$$x(t) = X \cos(\omega_b t + \theta); \quad X = |H(\omega)| \cdot Y$$

Displacement transmissibility (1)

Disp. transmissibility = $\frac{\text{Output disp.}}{\text{Input disp.}}$

$$\frac{X}{Y} = |H(\omega)| = \sqrt{\frac{1 + (2\zeta r)^2}{(1 - r^2)^2 + (2\zeta r)^2}}$$

Disp. Transmissibility specifies how motion is transmitted from the base to the mass at various driving frequency ω .

Displacement transmissibility (2)

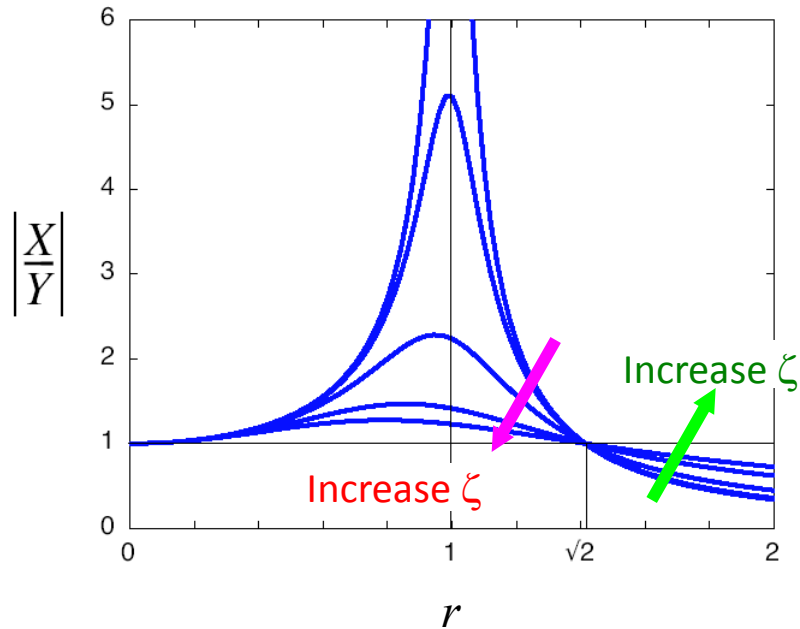

1. $r \approx 0 \Rightarrow$ D.T. ≈ 1
 2. $r \approx 1 \Rightarrow$ D.T. \rightarrow large
 3. $r < \sqrt{2} \Rightarrow$ D.T. > 1
Large ζ , small D.T.
- $r = \sqrt{2} \Rightarrow$ D.T. = 1
- $r > \sqrt{2} \Rightarrow$ D.T. < 1
Large ζ , large D.T.

$$\frac{X}{Y} = |H(\omega)| = \sqrt{\frac{1 + (2\zeta r)^2}{(1 - r^2)^2 + (2\zeta r)^2}}$$

Force transmissibility (1)

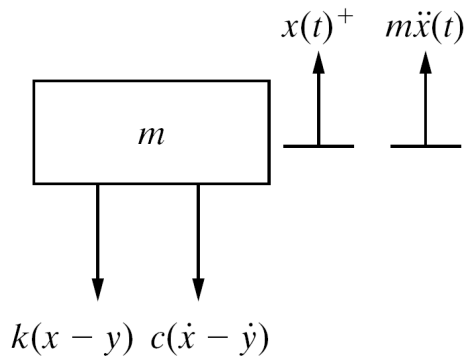

The force transmitted to the mass is done through the spring and damper.

$$F(t) = k(x - y) + c(\dot{x} - \dot{y})$$

From EOM

$$m\ddot{x} + c(\dot{x} - \dot{y}) + k(x - y) = 0$$

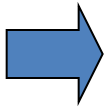

$$F(t) = c(\dot{x} - \dot{y}) + k(x - y) = -m\ddot{x}(t)$$

From

$$x(t) = |H(\omega)| \cdot Y \cos(\omega_b t + \theta)$$

$$\ddot{x}(t) = -\omega_b^2 \cdot |H(\omega)| \cdot Y \cos(\omega_b t + \theta)$$

$$\therefore F(t) = m\omega_b^2 \cdot |H(\omega)| \cdot Y \cos(\omega_b t + \theta) = F_T \cos(\omega_b t + \theta)$$

Force transmissibility (2)

$$F(t) = m\omega_b^2 \cdot |H(\omega)| \cdot Y \cos(\omega_b t + \theta) = F_T \cos(\omega_b t + \theta)$$

$$F_T = m\omega_b^2 \cdot |H(\omega)| \cdot Y$$

$$F_T = m\omega_b^2 \cdot \sqrt{\frac{1 + (2\zeta r)^2}{(1 - r^2)^2 + (2\zeta r)^2}} \cdot Y$$

$$F_T = kYr^2 \cdot \sqrt{\frac{1 + (2\zeta r)^2}{(1 - r^2)^2 + (2\zeta r)^2}} \quad \Rightarrow \quad \frac{F_T}{kY} = r^2 \cdot \sqrt{\frac{1 + (2\zeta r)^2}{(1 - r^2)^2 + (2\zeta r)^2}}$$

F.T. tells how much force is transmitted from the base to the mass at various driving frequencies

Force transmissibility (3)

$$\frac{F_T}{kY} = r^2 \cdot \sqrt{\frac{1 + (2\zeta r)^2}{(1 - r^2)^2 + (2\zeta r)^2}}$$

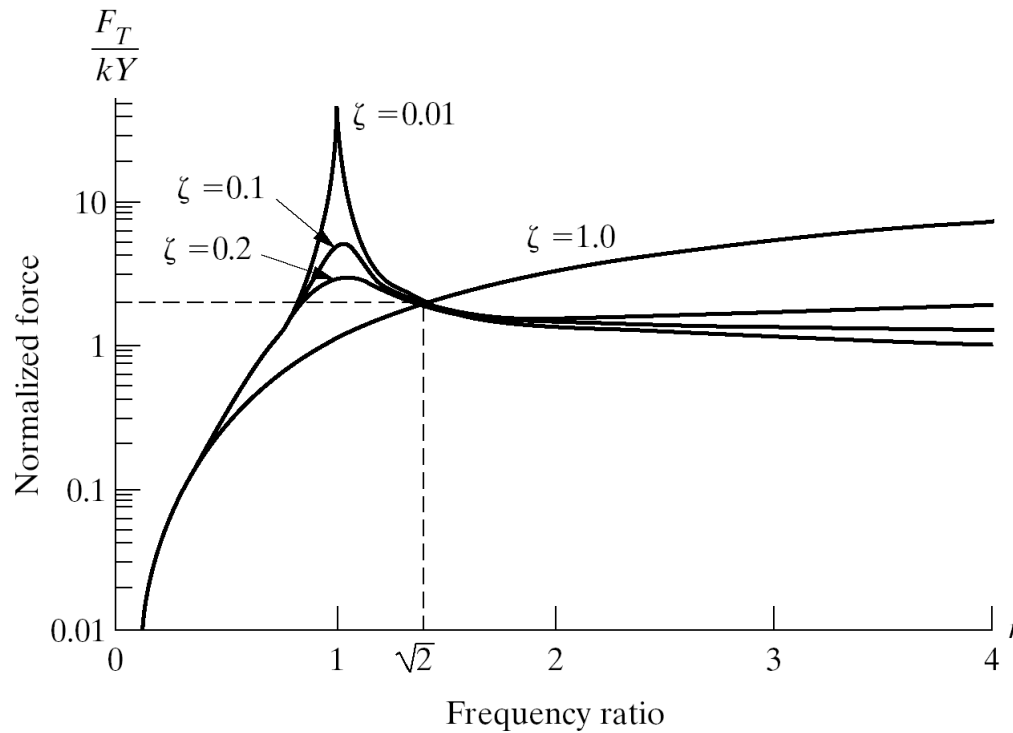

Example (Base excitation)

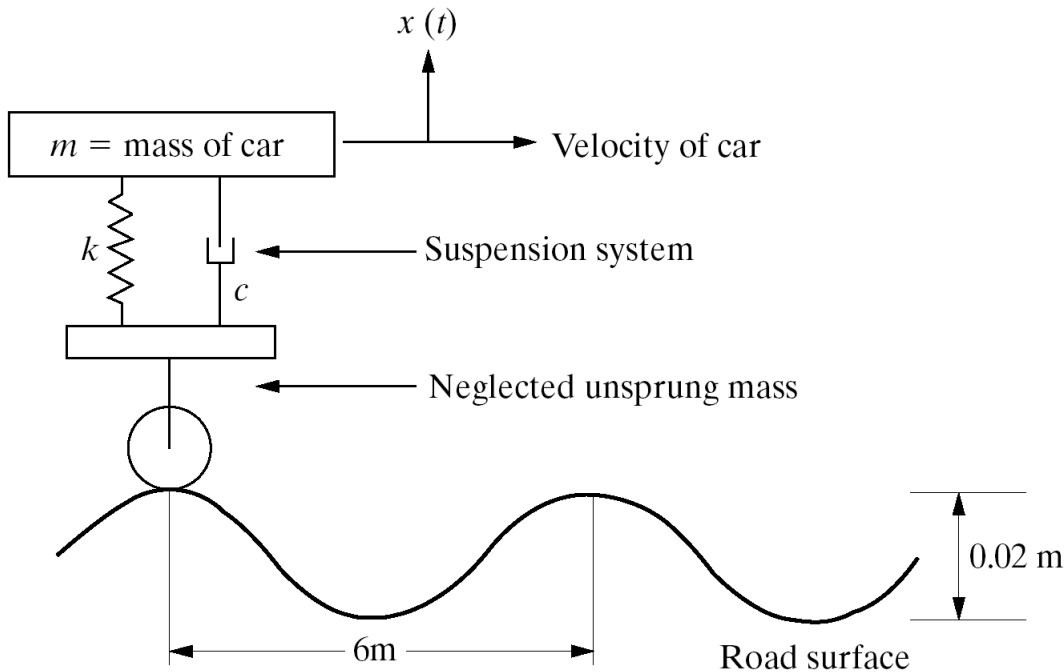

$$y(t) = (0.01) \sin \omega_b t \quad \text{m}$$

$$\omega_b = 0.2909v \quad \text{rad/s}$$

$$v \text{ (km/h)}$$

Determine the effect of speed on the amplitude of displacement of the automobile as well as the effect of the value of the car's mass. Assume that the suspension system provides an equivalent stiffness of $4 \times 10^5 \text{ N/m}$ and damping of $20 \times 10^3 \text{ N.s/m}$.

Example 2 (Base excitation)

Determine the amplitude of vertical vibration of the spring-mounted trailer as it travels at a velocity of 25 km/h over the road whose contour may be expressed by a sinusoid. The mass of the trailer is 500 kg and that of the wheels alone may be neglected. During loading, each 75 kg added to the load caused the trailer to sag 3 mm on its springs. Assume that the wheels are in contact with the road at all times and neglect damping. At what critical speed v_c is the vibration of the trailer greatest? [J. L. Meriam & L. G. Kraige 8/71]

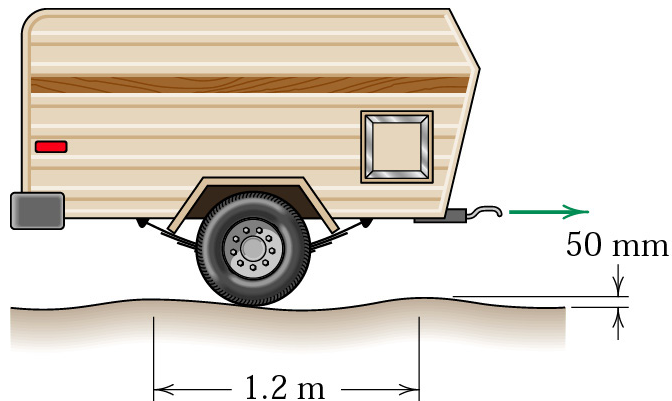

Measurement devices (1)

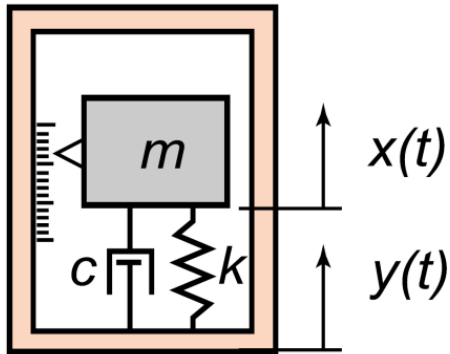

FBD

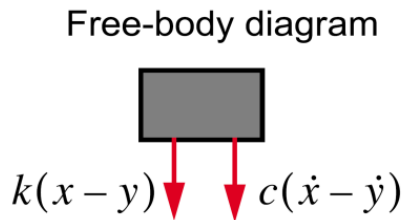

$y(t)$: Actual vibration of the interested object
 $x(t)$: Vibration of the mass m inside a measurement device

Measured value : $w(t) = x(t) - y(t)$

EOM $m\ddot{x} + c(\dot{x} - \dot{y}) + k(x - y) = 0$

$\Rightarrow m\ddot{w} + c\dot{w} + kw = -m\ddot{y}$

Assumption: the base moves harmonically

$$y(t) = Y \cos \omega t$$

Measurement devices (2)

$$m\ddot{w} + c\dot{w} + kw = -m\ddot{y} \quad \Rightarrow \quad \ddot{w} + 2\zeta\omega_n\dot{w} + \omega_n^2 w = -\ddot{y}$$

$$y(t) = Y \cos \omega t = \operatorname{Re}[Ye^{j\omega t}]$$

$$z(t) = Ze^{j\omega t}, \quad w(t) = \operatorname{Re}[z(t)]$$

Sub. into EOM to change to complex form

Complex EOM

$$\ddot{z} + 2\zeta\omega_n\dot{z} + \omega_n^2 z = \omega^2 Ye^{j\omega t}$$

$$(-\omega^2 + j2\zeta\omega_n\omega + \omega_n^2)Ze^{j\omega t} = \omega^2 Ye^{j\omega t}$$

$$Z = \left[\frac{\omega^2}{-\omega^2 + j2\zeta\omega_n\omega + \omega_n^2} \right] Y = \left[\frac{r^2}{1 - r^2 + j2\zeta r} \right] Y \quad r = \omega/\omega_n$$

Frequency response

$H(\omega)$

or

$T(\omega)$



Measurement devices (3)

$$Z = \left[\frac{r^2}{1 - r^2 + j2\zeta r} \right] Y = T(\omega) \cdot Y = |T(\omega)| e^{j\theta} Y$$

$$z(t) = Z e^{j\omega t} = |T(\omega)| e^{j\theta} Y e^{j\omega t} = |T(\omega)| Y e^{j(\omega t + \theta)}$$

$$w(t) = \text{Re}[z(t)] = |T(\omega)| Y \cos(\omega t + \theta) = W \cos(\omega t + \theta)$$

$$\frac{W}{Y} = |T(\omega)| = \frac{r^2}{\sqrt{(1 - r^2)^2 + (2\zeta r)^2}}$$



Measured vibration
Actual vibration

Displacement Transmissibility

Differ from “Displacement transmissibility” of base excitation

Seismometer

- Is used to measure displacement of vibration
- The value of $|T|$ approaches unity when r is large \rightarrow Seismometer region ($r > 3$)
- Low natural frequency (large mass or small k)
- Can measure in a range from 10 to 500 Hz with its natural frequency of 1 to 5 Hz

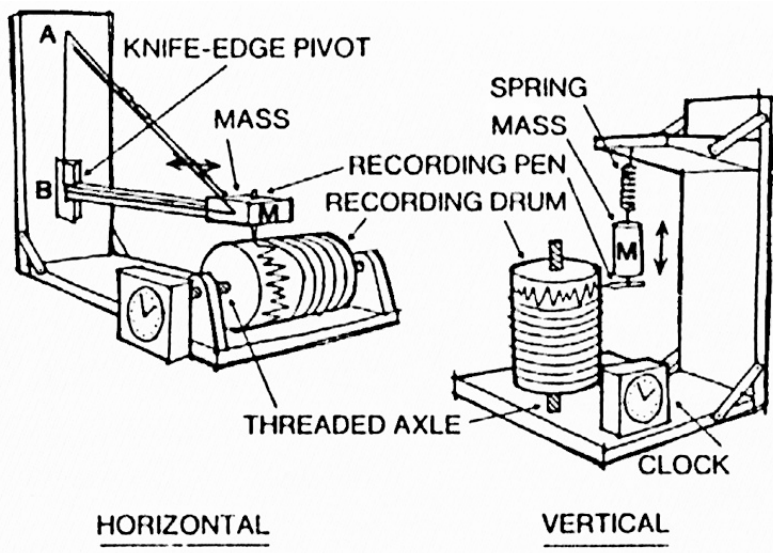

$$|T(\omega)| = \left| \frac{W}{Y} \right|$$

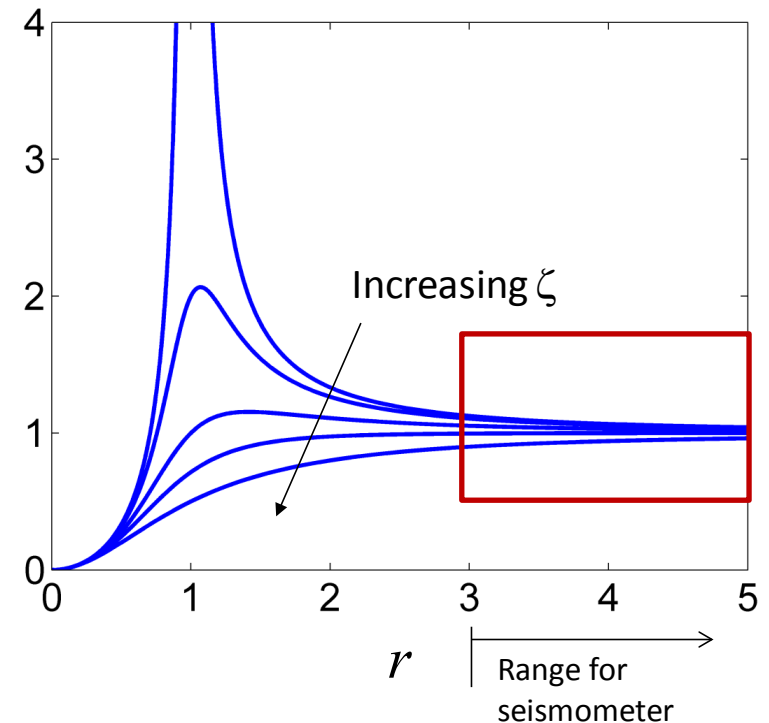

Accelerometer (1)



- Is used to measure acceleration of vibration
- Use piezoelectric effect:
Force (acceleration) \propto Voltage

$$\frac{W}{Y} = |T(\omega)| = \frac{r^2}{\sqrt{(1-r^2)^2 + (2\zeta r)^2}}$$

$$W = \frac{(\omega/\omega_n)^2 Y}{\sqrt{(1-r^2)^2 + (2\zeta r)^2}} = \frac{A_y / \omega_n^2}{\sqrt{(1-r^2)^2 + (2\zeta r)^2}}$$

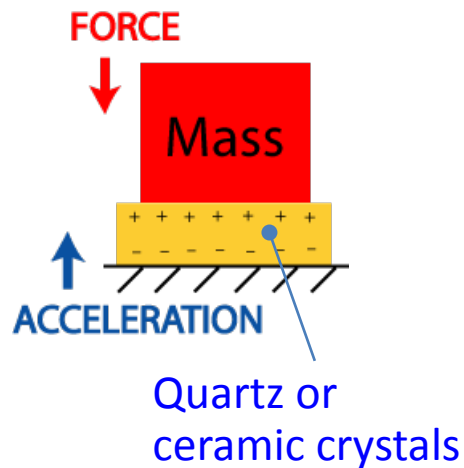

$$W \cdot \omega_n^2 = \frac{A_y}{\sqrt{(1-r^2)^2 + (2\zeta r)^2}}$$

Accelerometer (2)

- $|T|$ approaches unity when r is small \rightarrow accelerometer region
- Accelerometer range is widest when damping ratio = 0.65-7
($0 < r < 0.6$)
- High natural frequency (small mass and large k)
- Can measure in a range from 0 to over 10 kHz with its natural frequency of 30 to 50 kHz and weight less than 20 gm.

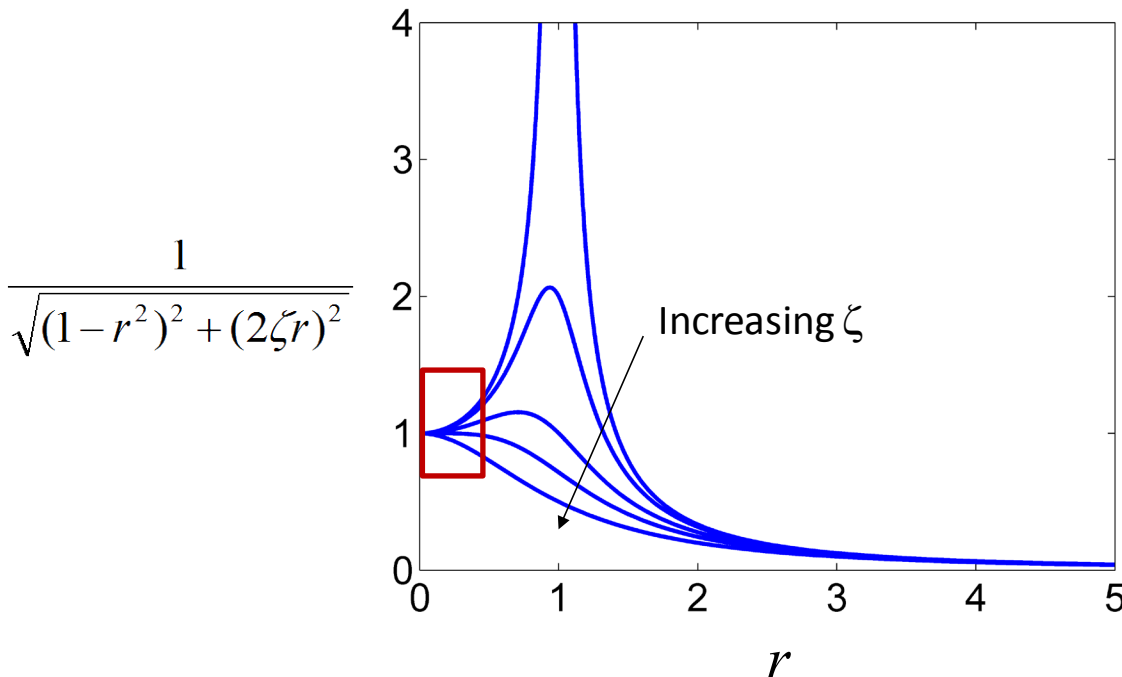

$$W \cdot \omega_n^2 = \frac{A_y}{\sqrt{(1-r^2)^2 + (2\zeta r)^2}}$$

Example : (Accelerometer)

An accelerometer has a suspended mass of 0.01 kg with a damped natural frequency of vibration of 150 Hz. When mounted on an engine undergoing an acceleration of 1 g at an operating speed of 6000 rpm, the acceleration is recorded as 9.5 m/s² by the instrument. Find the damping constant and the spring stiffness of the accelerometer. [Singiresu S. Rao, Ex 10.3]